

4

3

2

1

D

D

C

C

B

B

A

A

PRODUCED BY AN AUTODESK EDUCATIONAL PRODUCT

PRODUCED BY AN AUTODESK EDUCATIONAL PRODUCT

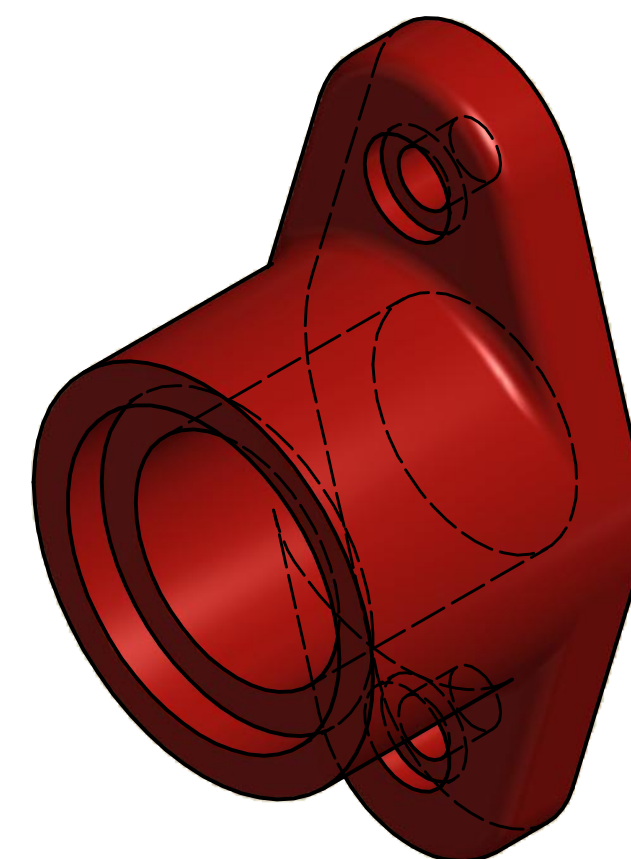
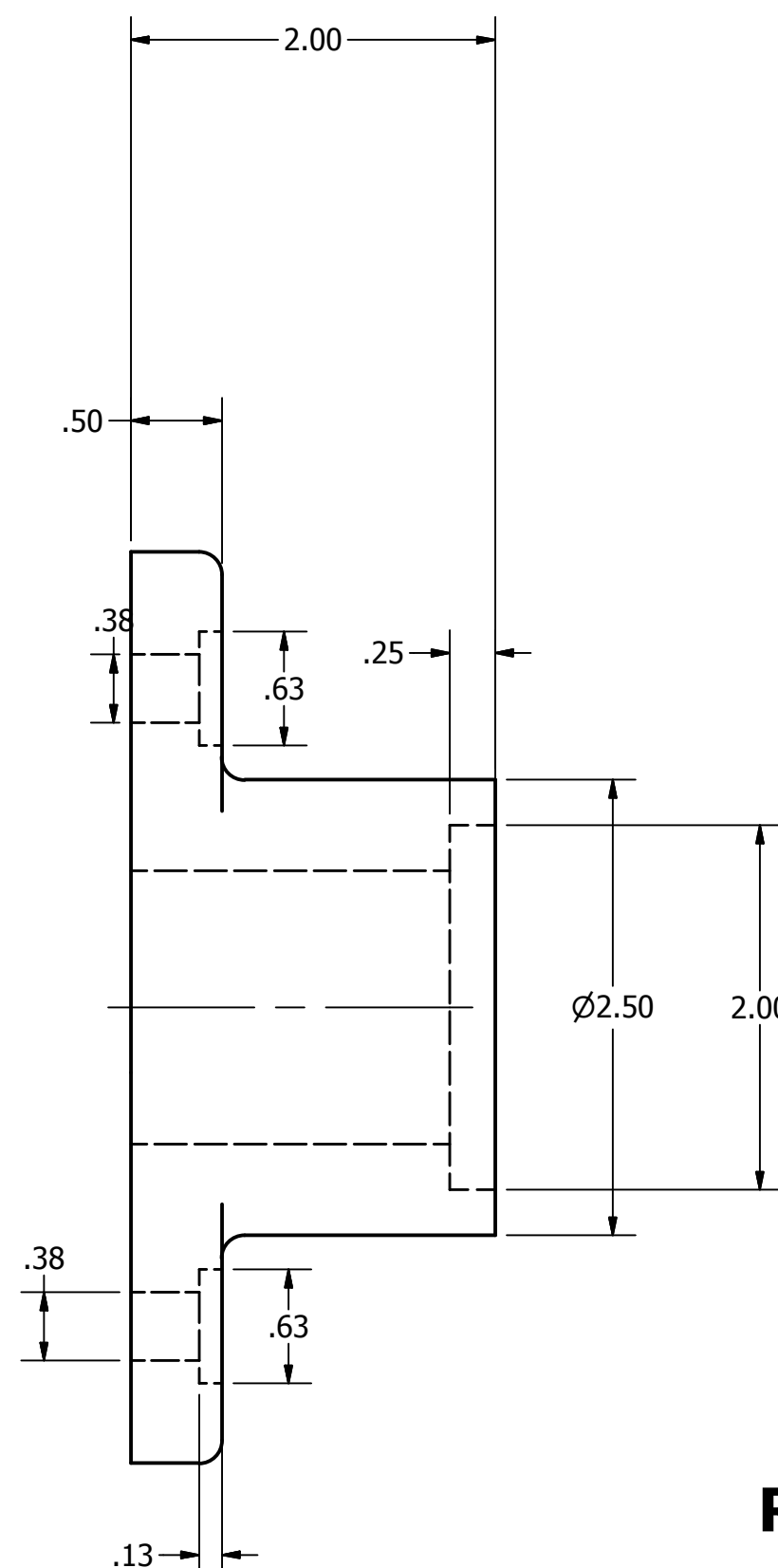
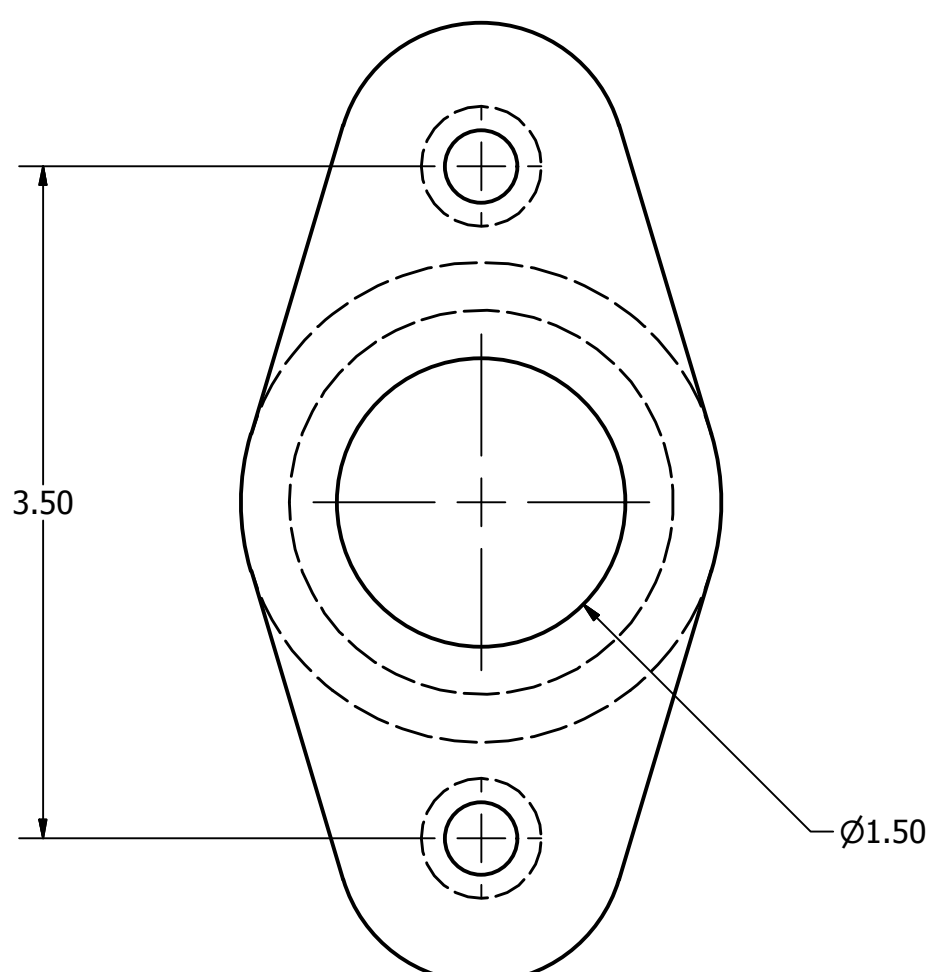
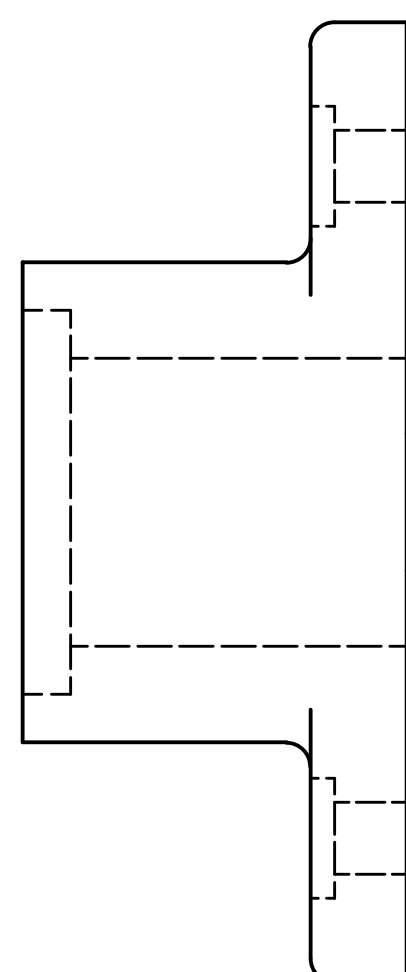

ROUNDS AND FILLETS R1/8

DRAWN HUNG PHU LUONG	5/17/2015	Introduction To Design	
CHECKED Hung Luong			
QA Period 5		Bearing (2) Shaft Support Assembly	
MFG			
APPROVED		SIZE C	DWG NO 5 Luong Hung Ch 13 Bearing (2) Shaft
		SCALE	REV SHEET 1 OF 1

4

3

2

1

4